



Innovator



Innovator TS6
2.4GHz 6CH Radio Control System
Instruction manual



Introduction

Congratulations on your purchase of the Innovator TS6 advanced 6 Channel 2.4GHz spread spectrum radio control system. This system was specifically designed with the latest wireless and TT advanced-programming technology to meet R/C helicopters requirements. With spread spectrum and smart frequency-hopping system, the Innovator TS6 radio system delivers precision & reliability in control without any interference risks.

This transmitter is exclusive for controlling the Innovator R/C helicopter; no receiver is included in this package since the receiver is built-in in the helicopter ICS control unit. So don't need extra receiver. If you like to use this transmitter to operate other models, you will need to acquire a matching receiver.

System Contents

- 1) Innovator TS6 Transmitter x 1
- 2) "Fly Mode" "Auto Rotation/CH6" sticker x 1
- 3) Instruction Manual x 1

Features

- **2.4GHz Frequency hopping spread spectrum wireless system**
Built with advanced frequency hopping program on the spread spectrum base to deliver system safety and reliability without interference risks.
- **Security ID binding link**
A binding feature is included with the Innovator 2.4 GHz spread spectrum system ensuring transmitter and receiver only recognize each other to prevent interferences from other controllers.
- **Interactive bi-direction Communication**
Adopt standard transceiver chips for interactive bi-direction communication between Tx/Rx.

- **Safety Power Cut-Off protecting function**
To prevent accidental shutting-off the transmitter, a unique feature guarantees the transmitter can not be turned off while the helicopter power is on.
- **Auto Cut-off Function**
In the event the transmitter power is let on after flight, the transmitter will automatically cut-off power after a pre-set period of time to save battery power.
- **Range checking function**
A range checking button on the transmitter reduces transmitter radiation power for doing range check before flight. It is recommended to do this checking before each flight.

Specifications

Transmitter	Innovator TS6
Configuration	Dual Sticks
Encoder	6Ch
Frequency(GHz)	2.4GHz
Modulation	GFSK
Current Drain	130mA@9.6V
Frequency Band Width	2402~2479MHz
Transmission System	FHSS
Band Number	78CH
ID Number	13 bit
Radio Speed	16Kbps
Simulator Port	Mini USB
Antenna Type	1/4 λ Dipole Sleeve
Antenna Peak Gain	2dBi Typical
Power Requirement	9.6V/8 cell AA Battery
Dimension (w/o Antenna)	180x180x70mm/7.08x7.08x2.76in
Weight (g/oz)	435g/15.37oz

Transmitter Controls

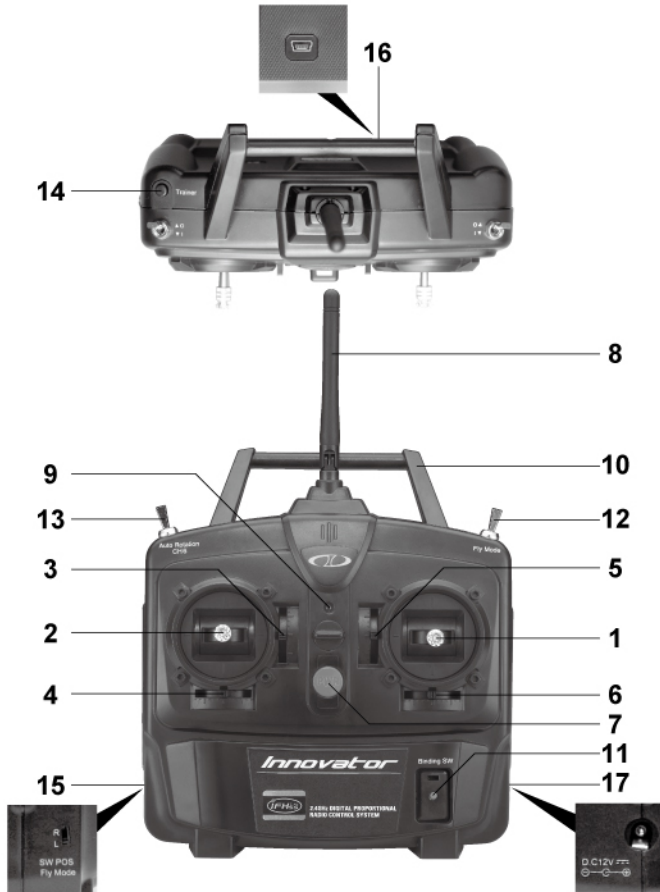

1. **Right Stick:** Throttle/Aileron control for Mode1 type. Elevator/Aileron control for Mode 2 type.
2. **Left Stick:** Elevator/Rudder control for Mode1 type. Throttle/Rudder control for Mode 2 type.
- 3~6. **Channel Trim TAB:** Trim tabs to trim controls to neutral position on each channel servo.
7. **Power Switch Button:** Turn the transmitter on or off.
8. **Antenna:** Bend the antenna up during flight.
9. **Voltage Indicator:** LED indicates the condition of the transmitter battery. When blinking, it indicates the batteries are getting weak. Change to new battery.
10. **Handle:** For carrying the transmitter..
11. **Binding Switch:** For performing binding process. Another function of this switch is for range checking function.
12. **Fly Mode Control Switch:** To switch Mode settings during flight.
13. **Auto Rotation/CH6 Control Switch:** To drive auxiliary 6th channel control such as auto rotation or others.
14. **Trainer Switch:** To switch primary control between student's and instructor's transmitter.
15. **Fly Mode POS Switch:** To match pilot's preferences, switch Fly Mode by toggling Left or Light settings.
16. **Simulator/Trainer mini USB Connector Port:** To connect transmitter to other by-wire devices.
17. **Charging Jack:** To recharge the transmitter battery pack (only use rechargeable Nicd or NiHM battery pack).

NOTE:

Set the ON/OFF switch on "OFF" position before charging. Charger must be plugged-in properly ("+" inside and "-" outside, type TAMIYA N-3U or equivalent). The wrong type of batteries may provoke explosion causing personal injuries and damages.

Installation

Transmitter batteries replacement/installation:

- 1) Slide the battery cover in the direction as shown to remove the cover.
- 2) Install 8pcs alkaline or rechargeable "AA" size cells into the battery holder connected to the transmitter.
- 3) Slide on the battery cover and make sure it is closed securely.
- 4) Turn the power on to check. If the Power Indicator LED fails to light, check the batteries for insufficient contact or incorrect battery polarity.



NOTE:

- a) Use only same brand, fresh, alkaline cells.
- b) Ensure all contacts in the battery holder are clean by using a pencil eraser to gently remove any corrosion or dirt that may accumulate. It is recommended to do this each time you install fresh cells into your transmitter.
- c) If using rechargeable 9.6V battery-pack. Remove the battery holder by pulling out the connector from the transmitter. Then plug-in the battery-pack connector to the transmitter.
- d) When rechargeable batteries are installed in the transmitter, these can be charged through the external charging jack located on the transmitter.

CAUTION:

- a) Do not attempt to charge alkaline batteries, they may explode!!
- b) When charging rechargeable batteries, turn off the power switch before charging. The charger plug must be of the correct type ("+" inside and "-" outside, type TAMIYA N-3U or equivalent). Incorrect charger plug type may provoke an explosion, causing personal injuries and damages.
- c) Always ensure batteries are loaded in the correct polarity. If the batteries are loaded incorrectly, the transmitter may be damaged.
- d) When the transmitter is not used for any short / long period of time, always remove the batteries from the transmitter.

Functions

The Innovator TS6 transmitter was specifically-designed to operate with the Innovator R/C helicopter. Basic functions for this transmitter are indicated below.

1.Power On

1.1 Turn On/Off

After installing the transmitter batteries, turn on the transmitter power by pressing the "PWR" switch button located on the front of the transmitter. Release upon hearing a short "Beep" tone confirming power is "On". The LED indicator will also turn red. To turn power off, press the "PWR" button and release upon hearing a long 'Beep" tone, confirming power is "Off". The LED indicator will also turn off.



1.2"Power Off Protection" function

Before operating the radio control model, always turn on first the transmitter, then power on the model. After flight, always turn off the model power first, followed by the transmitter. A built-in protecting function in the Innovator TS6 prevents you from accidentally turning off the transmitter while the model / helicopter power is still on.

1.3Auto Power-off

If the transmitter power is left on for 3 minutes after flight without transmitting stick movement signals, the transmitter will automatically cut-off to save battery power.

1.4Low Battery Power warning

If the transmitter battery power is too low, a short "Bi-Bi-Bi..." warning tone will buzz and the LED indicator will also flash. It's very dangerous to fly the model with a low battery transmitter. Land immediately and change batteries.

2.Stick Controls

Both the left and right sticks are designed to drive the 4 channels on the receiver/helicopter. Both Mode1 and Mode2 are available for the Innovator TS6 transmitter. Control functions are indicated below:

Mode	Left Stick		Right Stick	
	Up / Down	Left / Right	Up / Down	Left / Right
Mode 1	Elevator	Rudder	Throttle	Aileron
Mode 2	Throttle	Rudder	Elevator	Aileron

3.Fly Mode Control Switch

2 types of flying mode can be set up with different flying parameters on the Innovator control unit. Toggle Mode switch between modes. The switch is located on the upper right position. You also can use the "Fly Mode POS Switch" on the left side to toggle changes.



4.Auto Rotation/CH6 Control Switch

This switch drives the 6th channel control. On some models, it drives the "Auto Rotation" function.



5.Fly Mode POS Switch

Positions for both "Fly Mode" and "Auto Rotation/CH6" control switches can be interchanged. Default position is "R" with "Fly Mode" switch located on the right-up position / "Auto Rotation/CH6" switch is then located on the left-up position. Both positions can be reversed, with "Fly Mode" switch set on "L" (left-up position), and "Auto Rotation/CH6" switch set on "R" (right-up position).

2 additional "Fly Mode" and "Auto Rotation/6CH" stickers are included in the package for modifying original markings indicated on the transmitter.



Sticker

6. Binding Process

A binding feature is included in the Innovator 2.4 GHz spread spectrum system to ensure the transmitter and receiver bind properly and prevent interference from other controllers. With the Super Combo package, full binding procedure has been completed at the factory prior to shipping. To manually bind Tx/Rx, please proceed as per the following steps:



- Press and hold "Binding SW" button located on the right lower side of the transmitter.
- Simultaneously, turn on the power by pressing the "PWR" button until a short "Bi" tone confirms power is on.
- Release "Binding SW". The binding LED will blink rapidly, indicating the transmitter is binding.
- To perform binding process from the Innovator R/C helicopter, press and hold the push button on the Innovator helicopter, slide in the battery pack to turn on the helicopter/receiver power. Binding process will then start automatically.
- Successful binding is confirmed by the binding LED changing from a rapid blink to a slow flash on the transmitter. The LED will turn green on the receiver. Upon confirmation, turn off power on the helicopter and transmitter and launch normal start-up procedures.

NOTE:

Binding process may take 3~10 seconds to execute. If binding fails, the LED light on the receiver will turn red. Please turn off power and repeat the above steps from a) ~ e).

7. Range-Check

A built-in range-check function on the transmitter reduces signal strength for pre-flight range-check. When this function is activated, signal strength is weak. Use the weak signal strength for pre-flight range-check to confirm operation of wireless radio control system is normal. It is recommended to perform a complete range-check before every flight.

"Range-Check" procedure:

- Turn both transmitter and helicopter power on and ensure the system is functioning properly.
- Take the transmitter to a distance of about 20~30m from the model / helicopter.
- Press and hold the "Binding SW" button. Signal strength is now weak. The transmitter buzzer will signal with a short "Bi-Bi-Bi" warning tone. Please do not release "Binding SW" button at this stage.
- While still holding "Binding SW" button, operate both left and right sticks to drive movements on the helicopter's control linkages. Confirm that all movements are accurate and signal is interference-free.
- Release "Binding SW" button. Signal reverses back to full strength and warning tone stops.
- Helicopter is ready to fly.

Note:

Never push the "Binding SW" button during flight. Flying under weak signal strength will result in signal loss and model crash.

8. Flying the Simulator

Use a suitable interface device to connect the mini USB port (located on the back of the transmitter) to a personal computer and directly fly the Innovator on the simulator (simulator software sold separately).

9. Training Course

Use a suitable “buddy” cable to plug into the transmitter mini USB port and connect 2 transmitters (instructor and trainer) for flying lessons. The instructor can give full control to the trainer by holding down the “Trainer” button located on the top-left side of the transmitter. When released, full control is instantly returned to the Instructor.



FCC Interference Statement

This equipment has been tested and found to comply with the limits for a Class B digital device, pursuant to Part 15 of the FCC Rules. These limits are designed to provide reasonable protection against harmful interference in a residential installation.

This equipment generates, uses and can radiate radio frequency energy and, if not installed and used in accordance with the instructions, may cause harmful interference to radio communications. However, there is no guarantee that interference will not occur in a particular installation. If this equipment does cause harmful interference to radio or television reception, which can be determined by turning the equipment off and on, the user is encouraged to try to correct the interference by one of the following measures:

- Reorient or relocate the receiving antenna.
- Increase the separation between the equipment and receiver.
- Connect the equipment into an outlet on a circuit different from that to which the receiver is connected.
- Consult the dealer or an experienced radio/TV technician for help.

FCC Caution:

To assure continued compliance, any changes or modifications not expressly approved by the party responsible for compliance could void the user's authority to operate this equipment. (Example - use only shielded interface cables when connecting to computer or peripheral devices).

This device complies with Part 15 of the FCC Rules. Operation is subject to the following two conditions:

- (1) This device may not cause harmful interference, and
- (2) This device must accept any interference received, including interference that may cause undesired operation.

FCC Radiation Exposure Statement:

This equipment complies with FCC RF radiation exposure limits set forth for an uncontrolled environment.

This transmitter must not be co-located or operating in conjunction with any other antenna or transmitter.

Using Caution at the Flying Field

- Always perform a pre-flight range-check to ensure conditions are interference-free.
- Do not operate the model or use the radio in rain, lightning, or at night.
- Do not operate the model or use the radio if you have been drinking alcohol or under the influence of any other substance that could affect your skills and judgment.
- Always check battery charge before flight.
- Keep out of reach of children.
- Do not store the radio in temperatures below -10 °C (14°F) or above 40°C (104°F) or in a humid, dusty, or high vibration environment.
- Keep the radio away from direct sunlight.
- To prevent corrosion, remove batteries before storing the radio for a long period.

Accessories



AC2262
2.4G TX ANTENNA, TS6



AC2266
2.4G RX ANTENNA, TS6



AT0155
COACH CABLE, TS6



1085
NECK STRAP



2946-I
NI-MH BATT, 9.6V/1.1AH



2708
PC SOFTWARE WINTERFACE UNIT



AT2139
TxRx CHARGER, 110V2P/110mA
AT2139-J
TxRx CHARGER, 100V2P/110mA
AT2140
TxRx CHARGER, 230V2P/110mA
AT2141
TxRx CHARGER, 230V3P/110mA

Service

Thank you for purchasing the Innovator TS6 Radio. This radio was produced by Thunder Tiger Corp., a guarantee for high quality, services, and hours of trouble free operation from our R/C products.

Innovator is sold worldwide through authorized distributors supported directly by Thunder Tiger. To receive the latest product information ref. Innovator series products, and enjoy full technical support, please contact your nearest hobby shop or Innovator / Thunder Tiger authorized distributor.

Status Indication Chart

The following chart indicates LED and buzzer status. Do not operate your model if you suspect your radio is not working properly. If you encounter a signal not indicated on this chart and can not solve the problems by yourself, please contact your local Innovator or Thunder Tiger authorized distributor for service.

Status	Transmitter			Receiver
	Power LED	Binding LED	Buzzer	LED
Normal Operation	Red/Continuous	Green/Slow Flash	None	Green/Continuous
Low Battery	Red/Flash	Green/Slow Flash	Bi-Bi-Bi...	Green/Continuous
Range Checking	Red/Continuous	Green/Slow Flash	Bi-Bi-Bi...	Green/Continuous
Binding	Red/Continuous	Green/Rapid Blink	None	Red & Green Flash
Binding Success	Red/Continuous	Green/Flash	None	Green/Continuous
Binding Failed	Red/Continuous	Green/ Rapid Blink	None	Red/Continuous



Exclusive for the INNOVATOR R/C Helicopter
www.innovator-rc.com

Manufacture by **THUNDER TIGER CORP.**
www.thundertiger.com

CE 0681 ! FC

JC2151